

# ENERGIAAX

## GRID-TIED INVERTER

3 KW - 5 KW 1 P



Proudly, Truly Indian.

**OPERATING MANUAL**





## CONTENTS

COPYRIGHT DECLARATION . . . . .	2
1. NOTES ON THE MANUAL . . . . .	3
1.1 SCOPE OF VALIDITY . . . . .	3
1.2 HOW TO USE THIS MANUAL . . . . .	3
1.3 SYMBOL INDICATION . . . . .	3
1.4 SAFETY . . . . .	3
1.4.1 GENERAL SAFETY RULES . . . . .	3
1.4.2 PRECAUTIONS DURING INSTALLATION AND REPAIR . . . . .	3
1.4.3 PRODUCT SAFEGUARDING . . . . .	4
2. INTRODUCTION . . . . .	4
2.1 PRODUCT DESCRIPTION . . . . .	4
2.2 APPEARANCE . . . . .	4
2.3 PARTS LIST . . . . .	4
3. OPERATING INTERFACE . . . . .	5
3.1 DISPLAY PARAMETERS . . . . .	5
3.2 LED INDICATOR . . . . .	5
3.3 DISPLAY OVERVIEW . . . . .	6
3.4 BUTTONS . . . . .	6
3.5 TURNING ON THE INVERTER . . . . .	6
3.6 TURNING OFF THE INVERTER . . . . .	6
3.7 DATE AND TIME SETTING . . . . .	6
4. INSTALLATION . . . . .	7
4.1 LOCATION AND PLACEMENT . . . . .	7
4.2 INVERTER INSTALLATION . . . . .	8
4.3 PROCEDURE FOR INSTALLATION . . . . .	8
5. ELECTRICAL CONNECTIONS . . . . .	9
5.1 DC INPUT TERMINAL CONNECTION . . . . .	9
5.2 AC INPUT TERMINAL CONNECTION . . . . .	10
5.3 CONNECTION OF THE GROUND LINE . . . . .	12
5.4 MAX. OVER CURRENT PROTECTION DEVICE . . . . .	12
5.5 INSTALLATION OF DATA-LOGGER . . . . .	13
5.6 SURGE PROTECTION DEVICE (SPD) . . . . .	13
6. STARTING AND SHUTDOWN . . . . .	13
6.1 STARTING THE INVERTER . . . . .	13
6.2 INVERTER SHUTDOWN . . . . .	14
7. MAINTENANCE AND TROUBLESHOOTING . . . . .	14
7.1 VISUAL INSPECTION . . . . .	14
7.2 CLEANING THE INVERTER EXTERNALLY . . . . .	14
7.3 PV MAINTENANCE . . . . .	14
7.4 PV ARRAY CONFIGURATION RECOMMENDATION . . . . .	14
8. APPENDIX-1 GENERAL FAULTS AND THEIR SOLUTIONS . . . . .	15
9. APPENDIX-2 TECHNICAL SPECIFICATIONS - ENERGIAA X3 - 3KW GRID-TIED SOLAR INVERTER . . . . .	16
10. APPENDIX-3 VERSION HISTORY . . . . .	18

**COPYRIGHT DECLARATION:** The copyright of this manual exclusively belongs to STATCON ENERGIAA PVT. LTD. Any corporation or individual should not plagiarize, partially copy or fully copy (including software, etc.) it. Reproduction or distribution of it in any form or by any means is not permitted. All rights reserved. STATCON ENERGIAA PVT. LTD. reserves the right of final interpretation. This document is subject to changes without prior notice. This is valid only for ENERGIAAX series String Inverter PCUs and not for our other custom-built ratings.

# 1. NOTES ON THE MANUAL

## 1.1 SCOPE OF VALIDITY

This manual is an integral part of the string inverter, and it describes the assembly, installation, commissioning, maintenance and failure analysis/ troubleshooting of string inverter. The manual does not include complete information about the photovoltaic (PV) system.

## 1.2 HOW TO USE THIS MANUAL

Please read the manual and other related documents before carrying out any operation on the inverter. Keep this manual near the inverter for easy access by the operator/end user. Contents may be periodically updated or revised due to constant product improvement efforts. The information provided in this manual may be subject to change without notice. The latest manual can be acquired from [www.energias.in/downloads](http://www.energias.in/downloads)

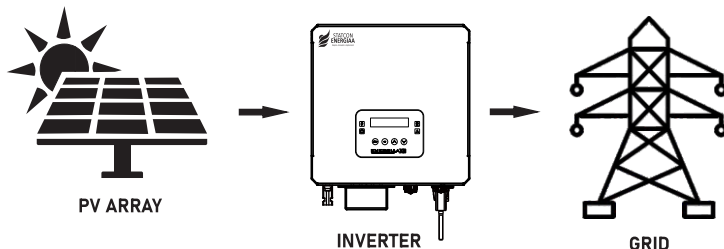

Figure-1.1 Application of inverter in PV power system

## 1.3 SYMBOL INDICATION

	<p><b>Danger!</b> "Danger" indicates a hazardous situation which, if not avoided, will result in death or serious injury.</p>		<p><b>Caution! Risk of electric shock!</b> Machine is working at high voltage. Do not touch it, as it may cause burn or electric shock to the nearest person.</p>
	<p><b>Warning!</b> "Warning" indicates a hazardous situation which could result in death or serious injury if not avoided.</p>		<p><b>Caution!</b> "Caution" indicates a hazardous situation which, if not avoided could result in minor or moderate injury.</p>

Table-1.1 Symbol indication

## 1.4 SAFETY

### 1.4.1 GENERAL SAFETY RULES

- Installation, maintenance & repair should be done by trained & experienced personnel only.
- Disconnect the grid & solar panel before any service on the inverter to avoid electrocution.
- Metal bracelets, rings and other metal objects should be removed before touching the inverter to avoid contact with electricity carrying items.
- Make sure the unit is inaccessible to small children to prevent them from being at risk of serious injuries.

### 1.4.2 PRECAUTIONS DURING INSTALLATION AND REPAIR

- Before installing the inverter, please check whether the product and its accessories are in complete order and whether there is obvious damage. If there is any anomaly, please contact the local dealer or Statcon Energias Pvt. Limited.
- Grounding of string inverter and panel should be done prior to making connections.
- Disconnect the circuit breaker or switch at the power grid side.
- Disconnect the PV string circuit breaker or switch at the DC input side.

### 1.4.3 PRODUCT SAFEGUARDING

- Inverter should be placed in accordance with the given instructions.
- Routine checks should be carried out to monitor the system health.
- The system works well in areas where temperature falls in range between 0°C to 55°C.
- Do not install the inverter under direct sunlight.
- There should be no contact of the inside of the inverter with liquid of any kind as it may result in a shorting of the circuit.
- Dust free areas are preferred otherwise the performance may deteriorate over time resulting in a system failure.

Note- "Please remove all packaging materials before installing the inverter."

## 2. INTRODUCTION

### 2.1 PRODUCT DESCRIPTION

Single phase String Inverter converts solar DC power into AC power which directly feeds the grid.

### 2.2 APPEARANCE

Front and bottom view of string inverter is shown in below figure-2.1 & 2.2.

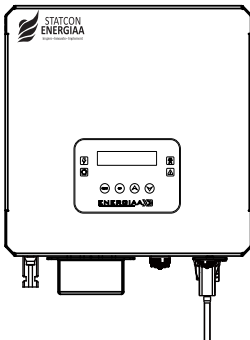

Figure-2.1 Front view

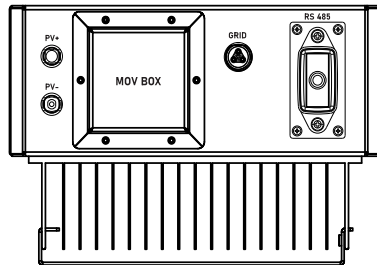

Figure-2.2 Bottom view

SR. NO.	PRODUCT	DIMENSIONS (IN MM) (W X D X H)	ENCLOSURE TYPE	COLOUR SHADE
1	STRING INVERTER	282 X 190 X 317 ±2mm	WALL MOUNTED TYPE	RAL5005 PLAIN TEXTURE

Table-2.1 Appearance of inverter

### 2.3 PARTS LIST

- Grid-tied string inverter
- Wall mounting bracket
- Stainless steel screws and expansion bolt
- AC and DC connectors
- User manual and warranty card
- Data-logger with Wi-Fi
- Test report

### 3. OPERATING INTERFACE

#### 3.1 DISPLAY PARAMETERS

- Solar Power
- Total Solar Generation
- Inverter Current & Temperature
- Grid Voltage & Frequency
- Time & Date
- PV Voltage & Current

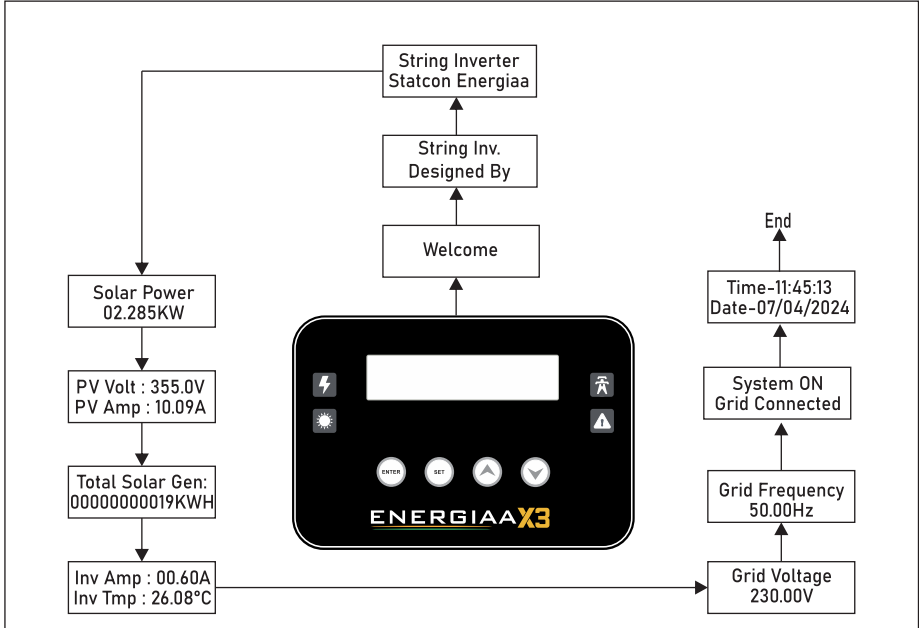

Figure-3.1 Front panel display



#### 3.2 LED INDICATOR

INDICATOR	LED COLOUR	STATUS	EXPLANATION
INVERTER ON	GREEN	ON	UNDER NORMAL OPERATION
		OFF	INVERTER OPERATION STOPPED
SOLAR	YELLOW	ON	SOLAR PV GENERATING
		OFF	SOLAR PV UNAVAILABLE
GRID	BLUE	ON	GRID CONNECTED
		OFF	GRID UNAVAILABLE
FAULT	RED	ON	FAULT DETECTED
		OFF	UNDER NORMAL OPERATION





Table-3.1 Status indicator lights

### 3.3 DISPLAY OVERVIEW

The display is located on the front panel of the inverter, which shows the following information:

- Check parameters after the inverter is switched ON.
- Press “Increment”  button to see each parameter.
- Press “Enter”  button to see fault messages.

### 3.4 BUTTONS

Sr. No.	Buttons Names	
1	ENTER	
2	SET	
3	INCREMENT	
4	DECREMENT	

### 3.5 TURNING ON THE INVERTER

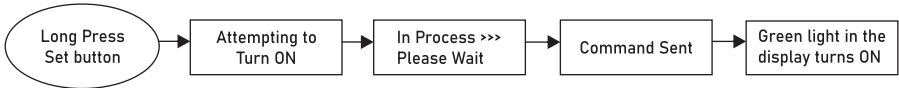

### 3.6 TURNING OFF THE INVERTER

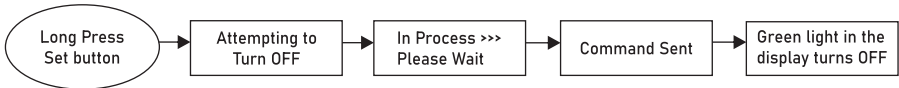

### 3.7 DATE AND TIME SETTING

- Long Press “Set + Increment + Decrement” buttons to go date and time setting.
- Press Set button successively to select time and date.
- Use the Increment and Decrement button to change the value.
- Press Enter button to exit from this mode.

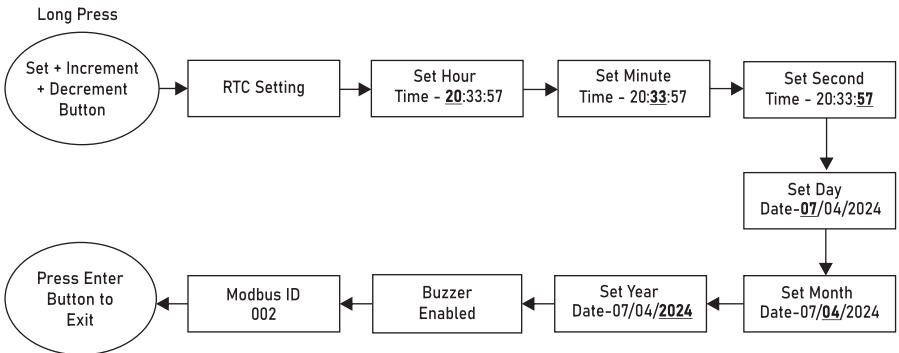

## 4. INSTALLATION

### 4.1 LOCATION AND PLACEMENT

To select a location for the inverter, the following criteria should be considered:

- Avoid installing the inverter in a potentially explosive atmosphere.
- Avoid installing the inverter in small closed spaces where air cannot circulate freely.
- Exposure to direct sunlight will increase the operational temperature of the inverter and may result output power limiting as well as expose the inverter body to UV rays. It is recommended that inverter is installed to avoid direct sunlight or rain (as shown in figure-4.1).
- Consider ambient air temperature when selecting the inverter installation location to prevent over heating. It is recommended to use sun shade, minimizing direct sunlight when the ambient air temperature around the unit exceeds 40°C.

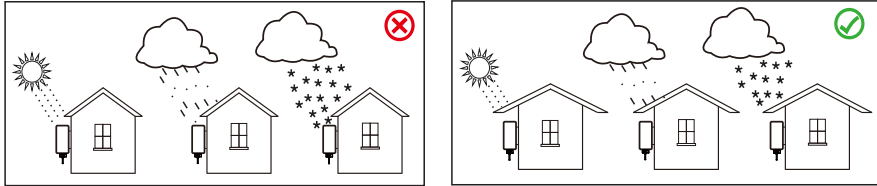

Figure-4.1 Installation position

- Mount the inverter on a wall or robust structure to bear the weight.
- Install vertically with a maximum incline of  $\pm 15^\circ$ . If the mounted inverter is tilted to an angle greater than this maximum angle, heat dissipation can be inhibited, and may result in less than expected output power (Installation angle shown in below figure-4.2).
- If installing more than one inverter, you must leave at least 500mm gap between each inverter.
- Keep out of bounds from small children.
- Consider whether the installation environment facilitates clear visibility of the inverter LCD display and indicator status clearly.

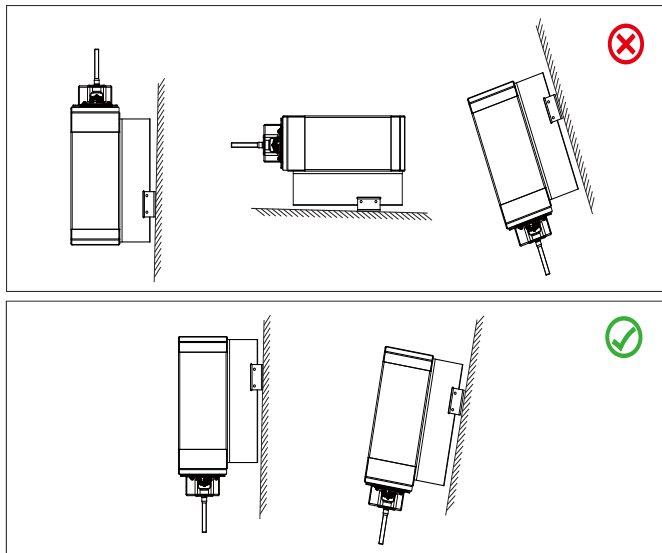

Figure-4.2 Installation angle



## 4.2 INVERTER INSTALLATION

The inverter is designed according to the wall mounted type installation, please use the expansion bolt for sturdy wall mounting.

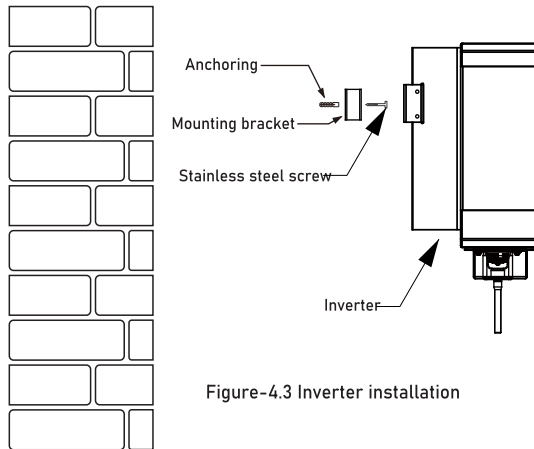

Figure-4.3 Inverter installation

## 4.3 PROCEDURE FOR INSTALLATION

- On the wall, locate the appropriate area for the Bolt's position on the mounting bracket, and then mark the hole.
- The wall/surface must be suitable for the expansion bolt installation. Ensure that the position of the installation holes on the wall is in accordance with the mounting bracket (as shown in figure-4.4).
- Hang the inverter to the top of the mounting bracket and then use the M4 screw in the accessory to lock the inverter heat sink to the mounting bracket, to ensure that the inverter will not move (as shown in figure-4.5).

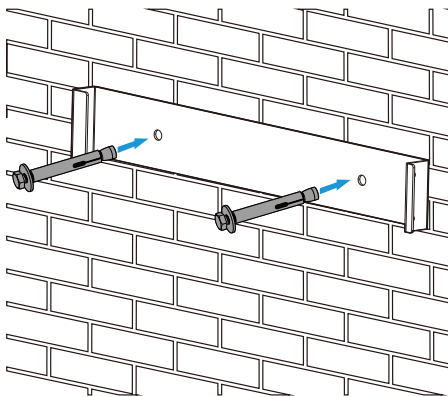

Figure-4.4

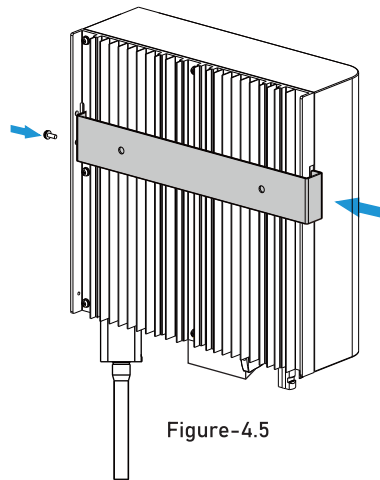

Figure-4.5

Inverter mounting bracket installation

## 5. ELECTRICAL CONNECTIONS

### 5.1 DC INPUT TERMINAL CONNECTION



**Warning !**

Before connecting PV modules, please ensure the PV+ & PV- of solar panel is not connected to the system ground bar.



**Safety Hint:**

Before connecting, please ensure the polarity of the output voltage of PV array matches PV+ & PV- symbols.



**Warning !**

Before connecting inverter, please ensure the PV array open circuit voltage is within the 450V of the inverter.

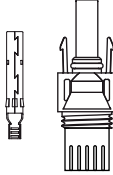

Figure-5.1 PV+ Male Connector

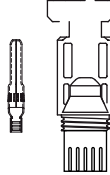

Figure-5.2 PV- Female Connector

Note- "Before connecting wires, ensure that all MCBs are switched OFF."



**Safety Hint:**

Please use approved DC cable for your inverter.

Cable type	Cross Section (mm <sup>2</sup> )	
	Range	Recommended Value
PV Cable	(4.0 ~ 6.0) (12 ~ 10 AWG)	4.0 (12 AWG)

Table-5.1 DC cable specification

STEP TO ASSEMBLE THE DC CONNECTORS ARE LISTED AS FOLLOWS:

- Strip off the DC wire about 7mm, disassemble the connector cap nut (as shown in figure 5.3).

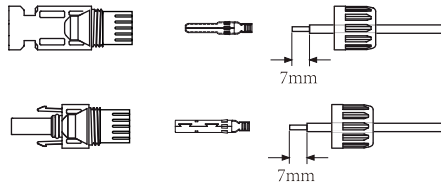

Figure-5.3 Disassemble the connector cap nut

- Crimp metal terminals using crimping plier (as shown in figure 5.4).



Figure-5.4 Crimp the pin to the wire

- Insert the contact pin into the top part of the connector, screw up the cap nut to the top part of the connector (as shown in figure-5.5).

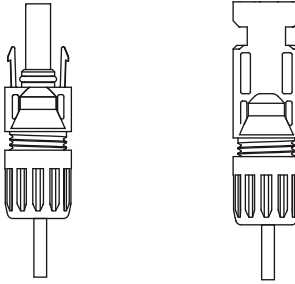

Figure-5.5 connector with cap nut

- Finally, insert the DC connector into the positive and negative inputs of the inverter (as shown in figure-5.6).



Figure-5.6 DC input connection

**Warning !**



Sunlight shining on the panel will generate voltage; high voltage in series may cause danger to life. Therefore, before connecting the DC input line, cover the solar panel with opaque material and ensure the DC switch is turned off. Otherwise, the high voltage of the inverter could pose life-threatening conditions.

**Warning !**



Use the DC power connector in the accessories supplied along with this inverter. Do not connect the connectors of different manufacturers.

**5.2 AC INPUT TERMINAL CONNECTION**

Do not close the DC switch immediately after connecting it; proceed to connect the AC connector, which can be easily connected. Recommended AC cable listed in table 5.2.

**Cable information**

CABLE CSA	CABLE OUTER DIAMETER	AWG	BREAKER	MAX CABLE LENGTH
2.5mm <sup>2</sup>	15-18mm	12	20A/230V	(L+N+PE) 20m

Table-5.2 Recommended AC cable specification

The AC output connector is segmented into three parts: matching socket, sleeve and sealing-sleeve, as shown in figure-5.7, the steps are as follows:

- Remove the cable sealing ring and sleeve sequentially from the AC connector.
- Separate the sleeves from the matching socket (as shown in figure-5.7). The connector body has two locking holes. Press the locking valve inward to detach the matching socket from the sleeve.

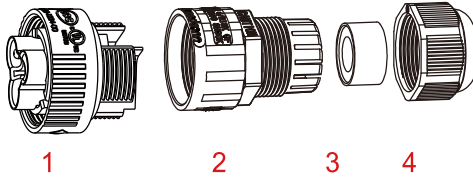

1. Matching Socket 2. Sleeve 3. Sealing Core 4. Sealing Nut

Figure-5.7 AC connector structure

- Use stripper to strip the protective sheath of the AC cable to the right length (as shown in figure 5.8).

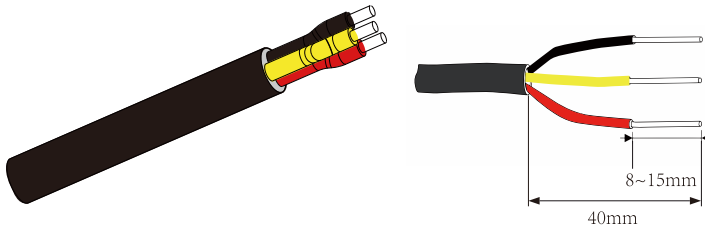

Figure-5.8 Strip AC cable



**Warning !**

Please pay attention to distinguish the L, N and PE of the AC Cables.

- Place the cable (L, N, PE) into the sealing sleeve.
- Open the bolts of the socket using a hexagon screwdriver, then insert each cable core into its corresponding jack. The labeling for AC connection terminal is shown in figure- 5.9.

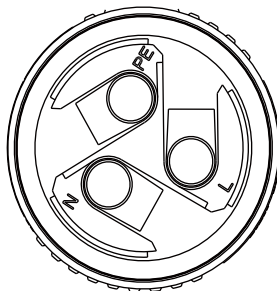

Figure-5.9 AC connector hole pattern

- Place the sleeve and sealing ring in position.
- Connect the terminals to the inverter as shown in figure-5.10.

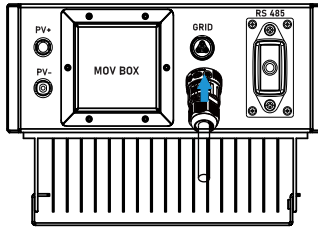

Figure-5.10 AC input connection

### 5.3 CONNECTION OF THE GROUND LINE

Proper grounding is good for resisting surge voltage shock and improving EMI performance. Therefore, before connecting AC, DC cables and data-logger, you need to ground the cable first. For a single system, simply ground the PE (Potential Earth) cable. For multiple machine systems, ensure that all the PE cables from the inverters are connected to the same grounding plate to ensure the equipotential connection. The installation of the ground wire is shown in figure-5.11.

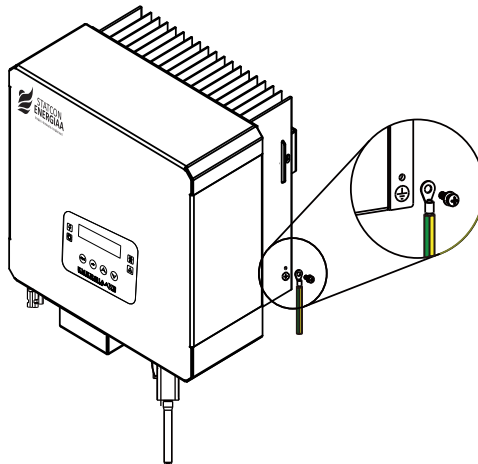

Figure-5.11 Installation of ground wire

### 5.4 MAX. OVER CURRENT PROTECTION DEVICE

In order to protect the inverter AC and DC connection, it is recommended to install a circuit breaker to prevent over current (See below table-5.3 & 5.4) .

#### FOR AC CONNECTION

INVERTER	RATED VOLTAGE (V)	RATED CURRENT (A)	CURRENT FOR PROTECTION DEVICE (A)
String Inverter 3KW	230	13	20

Table-5.3 Recommended circuit breaker for AC side

#### FOR DC CONNECTION

INVERTER	RATED VOLTAGE (V)	RATED CURRENT (A)	CURRENT FOR PROTECTION DEVICE (A)
String Inverter 3KW	450	13	19

Table-5.4 Recommended circuit breaker for DC side

## 5.5 INSTALLATION OF DATA-LOGGER

When installing the data-logger, remove the sticker first. Insert the data-logger, as per correct connector orientation and tighten the screws to hold it tightly in position. When the inverter PV power is on, an orange LED will light up in the data-logger, indicating normal operation. The installation of the data-logger shown in figure-5.12.

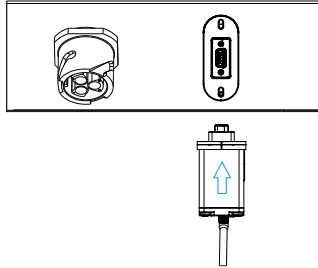

Figure-5.12 Data-logger Installation

## 5.6 SURGE PROTECTION DEVICE (SPD)

Surge protection device is used to protect the inverter from electrical surges such as lightning or other surge events, which are unpredictable and may harm the inverter and its components.

It is recommended to use both AC and DC surge protection device as listed in table-5.5.

SURGE PROTECTION DEVICE	DESCRIPTION
For AC Side	AC SPD DS100R-230V
For DC Side	Solar DC SPD VAL MS 1000DC-PV 2+V (Black) 2800624Electrical Fuse (20-40A)

Table-5.5 Recommended surge protection device

## 6 STARTING AND SHUTDOWN

Before starting the inverter, ensure it meets the following conditions; otherwise, it may result in fire or damage to the inverter, resulting in inverter warranty being void.

Total output power of PV shall not exceed the maximum of inverter as mentioned in inverter datasheet.

### 6.1 STARTING/ ENERGIZING THE INVERTER

Must follow below steps while starting the inverter :

STEP 1- Turn on the DC switch of the PV module, and if the panel provides sufficient starting voltage and power, the inverter will start.

STEP 2- Turn on the AC switch.

STEP 3 - Check for "System ON" on display. If "System OFF" follow section 3.5.

STEP 4- The inverter will first examine internal parameters and the grid parameters.

If the parameters are within acceptable range, the inverter starts generating energy and you will see the green light LED in the display turns ON.

## 6.2 INVERTER SHUTDOWN

Must follow below steps while shutting down the inverter :

STEP 1 - Turn off the inverter, follow section 3.6.

STEP 2 - Turn off the AC switch (if any), or simply disconnect the AC input connector.

STEP 3 - Turn off the DC switch (if any), or simply disconnect the DC input connector.

The inverter shuts down within two minutes.

## 7. MAINTENANCE AND TROUBLESHOOTING

### 7.1 VISUAL INSPECTION

- ✓ Check the inverter and cables for any visible damage and monitor the operating status display of the inverter. Before maintenance, you must disconnect AC and DC to avoid risk of any shock.
- ✓ If there is any damage, please inform your dealer accordingly.



**Safety Hint:**

Please Carry out visual inspection at least once or twice a year.

### 7.2 CLEANING THE INVERTER EXTERNALLY

- ✓ Only use completely dry cloth/tissue to clean the inverter.
- ✓ Only the exterior of the inverter should be cleaned.
- ✓ Use a soft and dry brush to remove dust from the top side of the inverter on a regular basis.

### 7.3 PV MAINTENANCE

- ✓ PV Panel surface should be clean.
- ✓ Regularly inspect the PV panel to ensure it receives optimal sunlight exposure.

### 7.4 PV ARRAY CONFIGURATION RECOMMENDATION

SR. NO.	PV MODULE	STRING CONFIGURATION
1	335Wp	9M (S) X 1P
2	500Wp	6M (S) X 1P

Note : Voc of inverter is 100-450V

**APPENDIX-1 GENERAL FAULTS AND THEIR SOLUTIONS**

<b>FAULT NAME</b>	<b>DESCRIPTION</b>	<b>REMEDY/ACTION</b>
Grid Over Volt	When grid supply voltage goes above the over- voltage set value	Check the grid voltage
Grid Under Volt	When grid supply voltage goes below the under- voltage set value	Check the grid voltage
Grid Over Freq	When grid supply frequency goes above the over- frequency set value	Contact your DISCOM to rectify your grid supply
Grid Under Freq	When grid supply frequency goes below the under- frequency set value	Contact your DISCOM to rectify your grid supply
INV. Over Current	This fault occur due to internal fault of inverter or due to loose connections or due to some voltage transient	Check all the connections of string inverter
Diff. Current Unbalance	Inverter current unbalance	Check PV panel insulation level/check the earth connection of the inverter
System Over Temp	This fault may occur due to high ambient temperature or if cooling/ ventilation is not proper for the inverter	Install the inverter in proper ventilated area
PV Over Voltage	When PV panel or PV string voltage connected beyond the maximum allowed PV voltage range value	Check the PV rating
PV Under Voltage	When PV panel or PV string voltage connected beyond the minimum allowed PV voltage range value	Check the PV rating
DC Over Voltage	When DC voltage goes above the over voltage set value or due to some voltage transient	Check the DC voltage
DC Under Voltage	When DC voltage goes below the under voltage set value or due to some voltage transient	Check the DC voltage
Earth Fault	Due to improper earth connection	Check all the connections of string inverter



**APPENDIX-2 TECHNICAL SPECIFICATIONS - ENERGIAA X3  
3KW GRID-TIED SOLAR INVERTER**

Model No.	Energiaa X3
<b>INPUT SIDE</b>	
Max. DC Input Voltage	450V
Max. Recommended DC Power	3.15KW
Start-Up DC Input Voltage	100V
Nominal Voltage	380V
MPPT Operating Range (Voc)	100-450V DC
Max. DC Input Current	13A
Max. Short Circuit Current	19A
Number of MPPT	One
Number of String per MPPT	One
<b>OUTPUT SIDE</b>	
AC Nominal Power	3KW
Max. AC Apparent Power	3KVA
Nominal AC Voltage (Range)	230V (180-265V)
AC Grid Frequency (Range)	50Hz (47.5-52.5Hz)
Operating Phase	Single Phase
Max. AC Output Current	13A
Output Power Factor	Unity
Grid Current THD	<3% *
<b>EFFICIENCY</b>	
Max. Conversion Efficiency	>97.5%
MPPT Efficiency	>99.5%
<b>GENERAL DATA</b>	
Dimensions (W X D X H)	(282 x 190 x 317) ±2 mm
Weight	7.45Kg
Topology	Transformerless

Operating Temperature	(-10 ~ 55) °C
Night Time Power Consumption	< 1W
Cooling	Natural Convection
Ingress Protection	IP-65
Relative Humidity	0~100%
DC Connection	MC4
AC Connection	Connector
Display	16 X 2 LCD
Interface	RS485/Wi-Fi
Warranty	60 Months/ 5 Years **
<b>PROTECTION</b>	
Grid Monitoring	Yes
Anti-Islanding	Yes
Differential Current Monitoring	Yes
AC Short Circuit Protection	Yes
DC Surge Protection	Yes
Insulation Resistance Monitoring	Yes
AC Surge Protection	Yes
<b>Note : Specification are subject to change prior notice due to constant improvement in design and technology</b>	
<b>* As per the IEC 61727 Standards.</b>	
<b>** Warranty period and T&amp;C as per the Warranty Card supplied along with the product.</b>	

### APPENDIX-3 VERSION HISTORY

VERSION HISTORY DETAILS			
VER. NO.	RATING/MODEL NO.	DATE	COMMENTS
Version 1.2	3KW String Inverter (Energiaa X3)	19-04-2024	No Comments



**STATCON  
ENERGIAA**

Inspire + Innovate + Implement

B-81, Sector-63, Noida, G.B. Nagar-201307 (U.P.) - INDIA

Phone : +91-120-4088600, Toll Free : 1800 891 3319

Website : [www.energias.in](http://www.energias.in)

Customer Support : [servicing@energias.in](mailto:servicing@energias.in)

**Solar | Power | Defence | Railway | Hydrogen**